

TOP VIEW

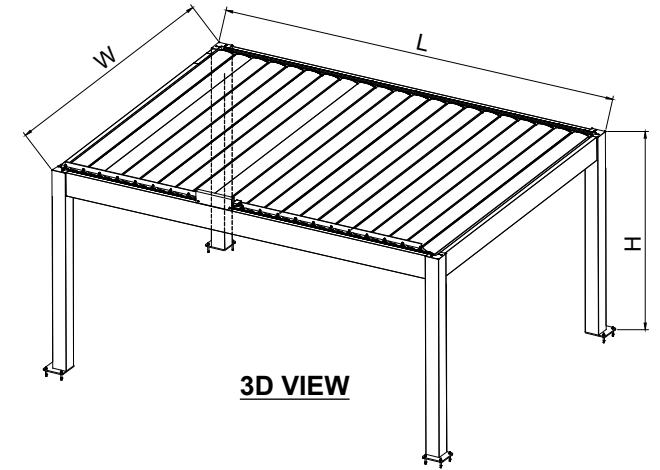

3D VIEW

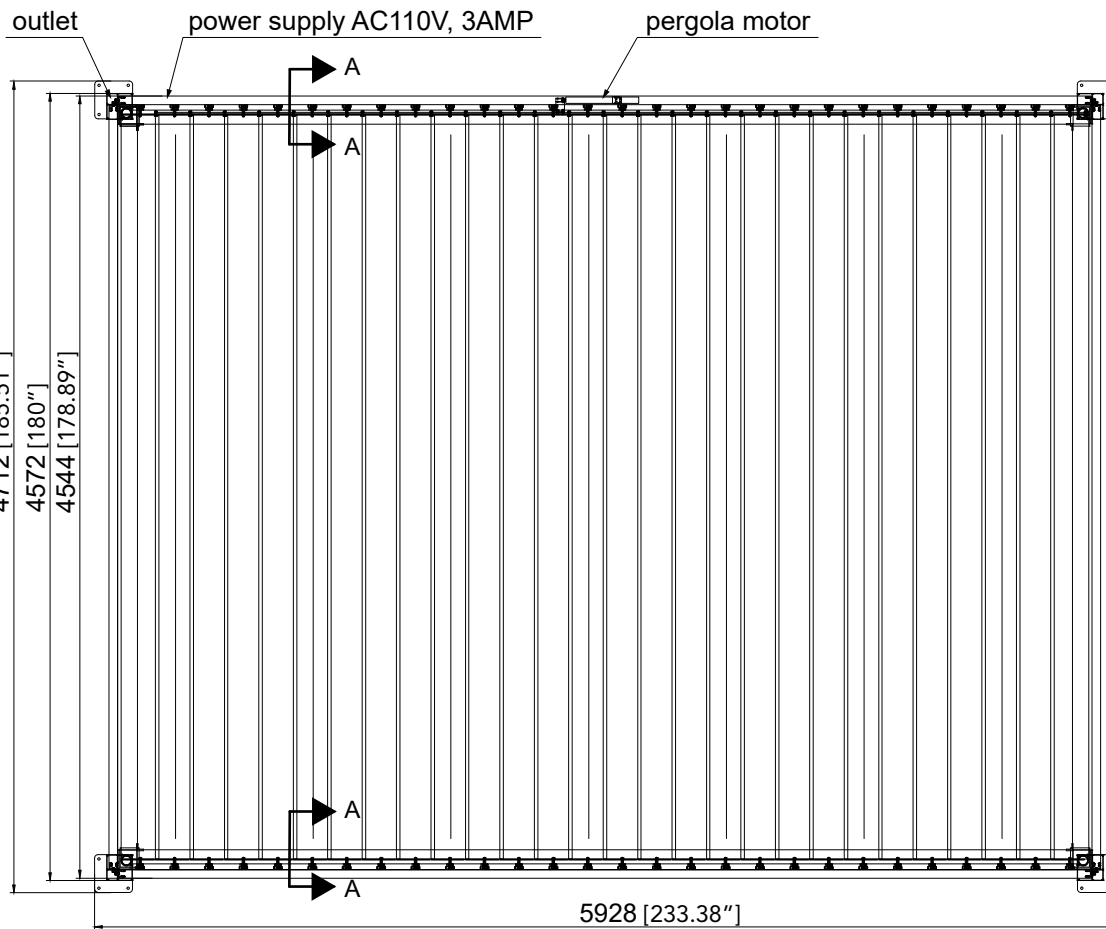

LATERAL VIEW 2

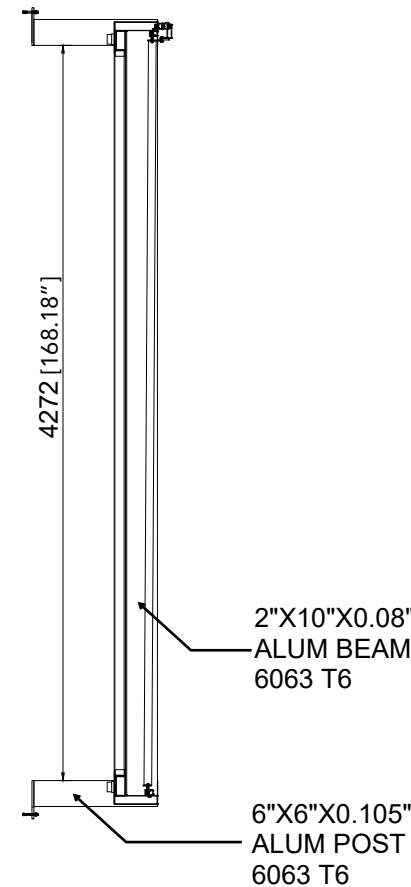

LATERAL VIEW 1

L = 5788[227.87"]
 W = 4572[180"]
 H = 2993[117.83"]

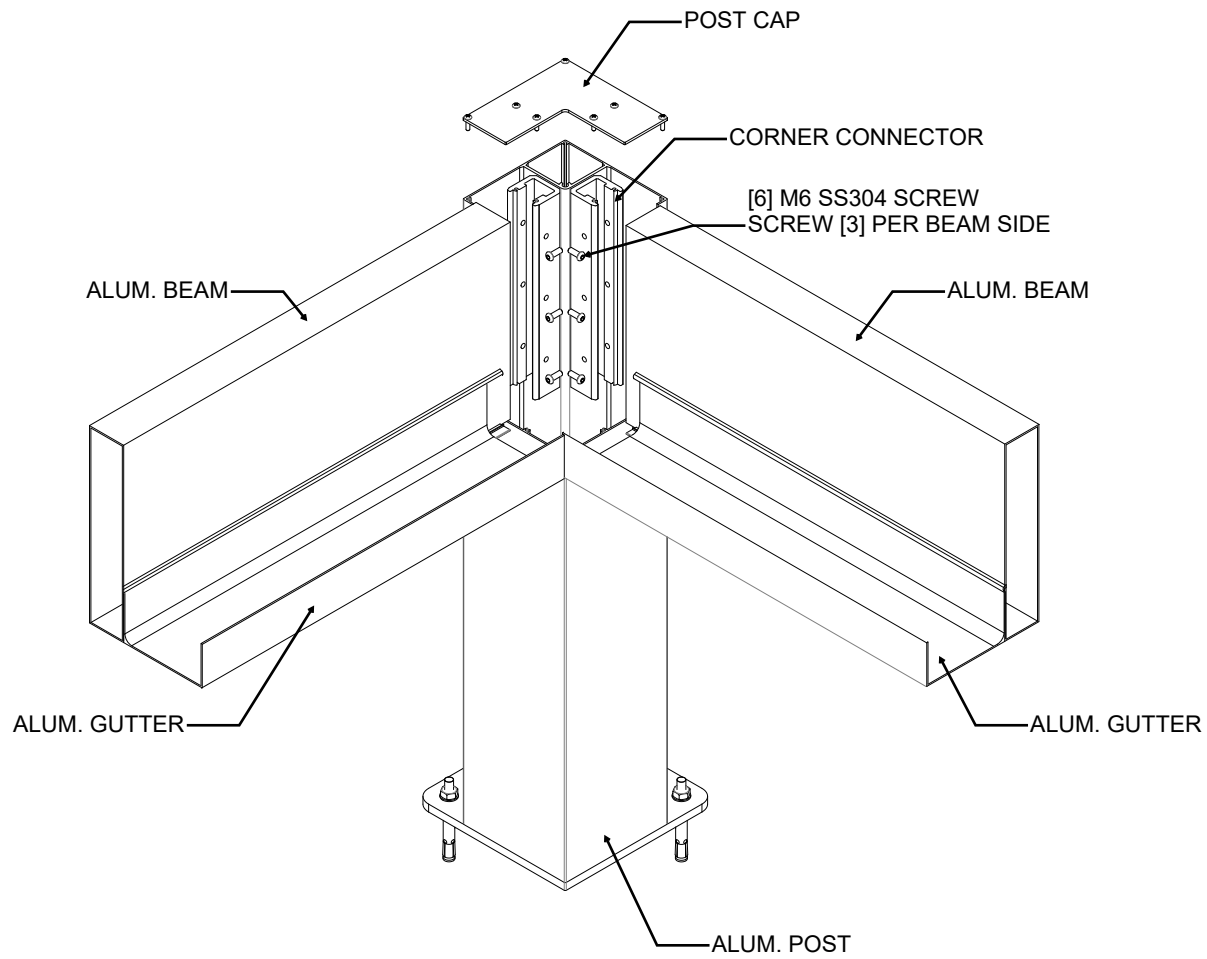

BEAM-POST CONNECTION

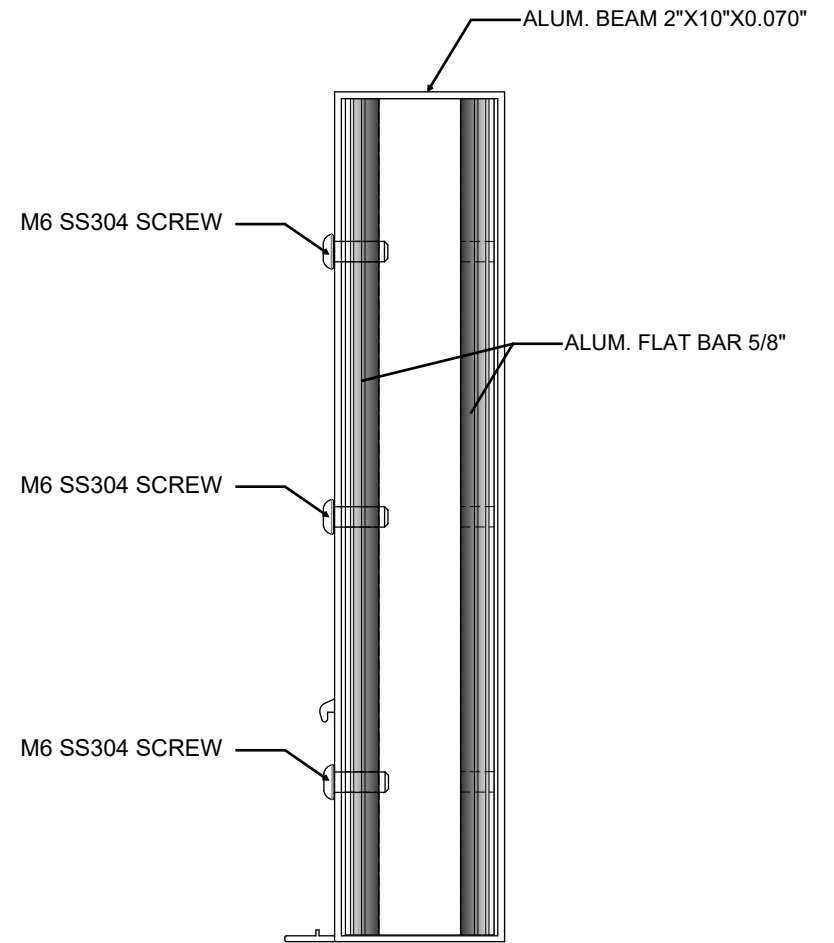

**SECTION A-A
LOUVER BEAM REINF. DETAIL**

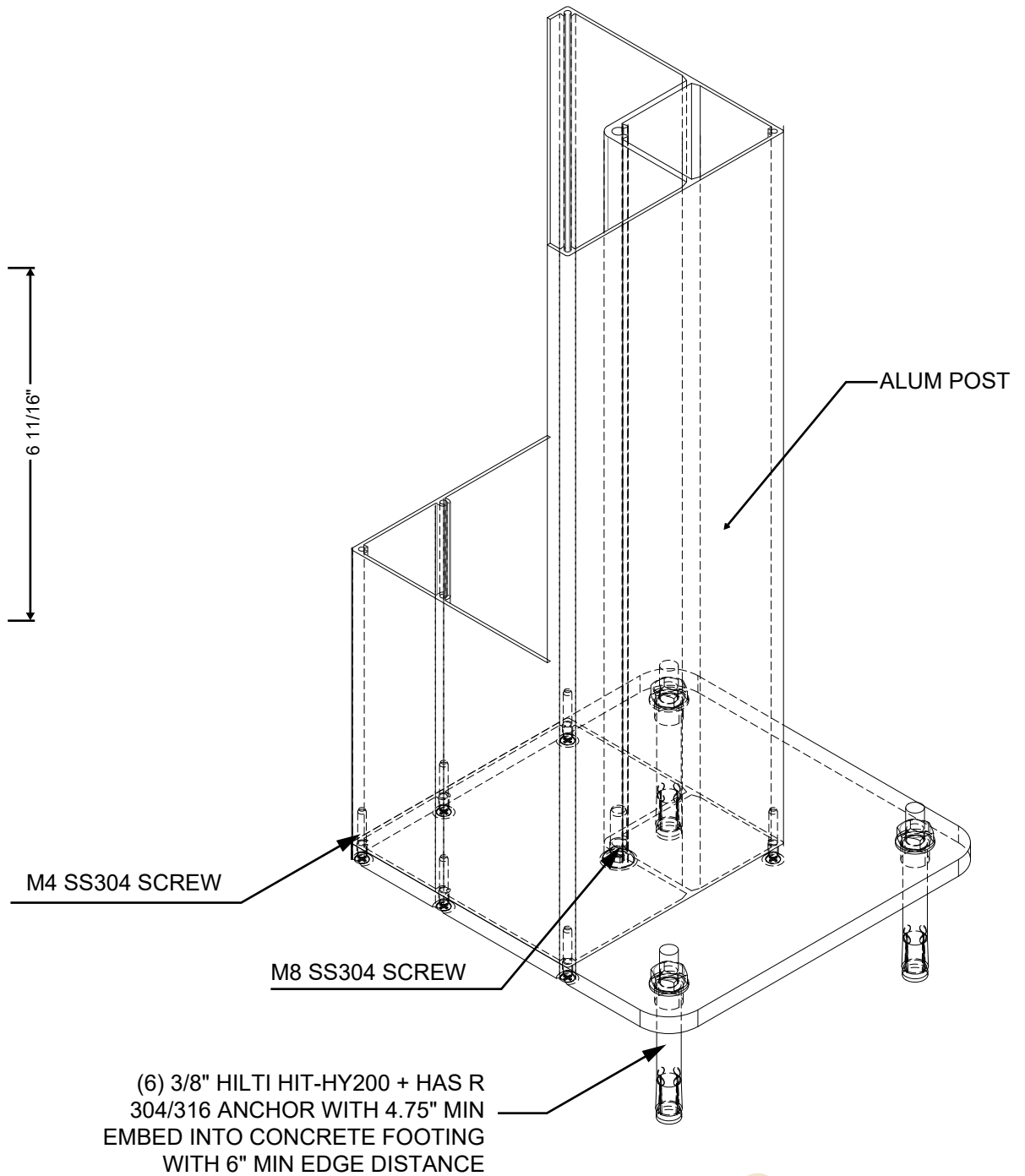
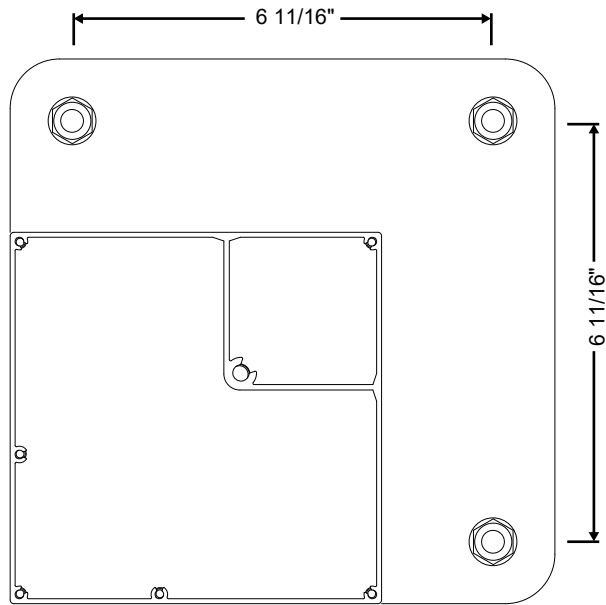

ALL EXTRUSIONS ALUMINUM 6063 T5

| | | | | | | | | | | | | | | | | | | | | | | | | | | | | |
|---|---|---|---|---|---|---|---|---|----|----|----|----|----|----|----|----|----|----|----|----|----|----|----|----|----|----|----|--|
| 1 | 2 | 3 | 4 | 5 | 6 | 7 | 8 | 9 | 10 | 11 | 12 | 13 | 14 | 15 | 16 | 17 | 18 | 19 | 20 | 21 | 22 | 23 | 24 | 25 | 26 | 27 | 28 | |
| | ■ | | | | ■ | | | | ■ | | | | ■ | | | | ■ | | | | ■ | | | | ■ | | | |

7 light strips in total

| Blade | Blade | Gutter | Beam | Column | Footing Plate |
|-------|-------|--------|------|--------|---------------|
| | | | | | |

EXTRUSIONS